



Senju Sprinkler

Model FR-RES

K-Factor: 4.9 • SIN: SS4451

Residential Pendent and
Recessed Pendent Sprinkler



GENERAL DESCRIPTION

The Model FR-RES Residential Pendent and Recessed Pendent Sprinklers are fusible link type automatic sprinklers. They are durable and fast responding. The Model FR-RES is designed for residential occupancies and is perfect for use in homes, hotels and other living quarters.

The Model FR-RES is to be used in wet pipe residential sprinkler systems for One- and Two- Family Dwellings and Manufactured Homes per NFPA 13D; wet pipe residential sprinkler systems for Residential Occupancies up to and Including Four Stories in Height per NFPA 13R; or, wet pipe sprinkler systems for the residential portions of any occupancies per NFPA 13.

The Model FR-RES has a 4.9 (70.6 LPM/bar^{1/2}) K-factor that meets the required residential flow rates with minimal residual pressure, which allows for smaller pipe sizes and water supply requirements.

For extended installation flexibility, the Model FR-RES provides 1/2 inch (12.7mm) vertical adjustment with the D1 or D3 Recessed Escutcheon.

Notice: The heat sensitivity and water distribution design of Model FR-RES allows for an increased chance of residents to escape or evacuate in case of a fire. However, residential fire sprinkler systems are not a substitute for fire safety awareness or fire safety construction required by building codes.

WARNINGS

The Model FR-RES must be installed and maintained in accordance with the rules stated herein as well as in compliance with the applicable standards of the National Fire Protection Association regulations and the standards of any other authorities having jurisdiction.

In the event of this condition, consult the authorities having jurisdiction for guidance and approval. Failure to do so may impair the integrity of these devices.

It is the responsibility of the installing contractor to provide a copy of this document to the owner or their representative, and in turn, it is the obligation of the owner to provide a copy of this document to a succeeding owner.

The owner is responsible for maintaining their fire protection system and devices in proper operating condition. The installing contractor or sprinkler manufacturer should be contacted with any related questions.

TECHNICAL DATA

- **Approvals:**
 - cULus Listed
- **Sprinkler Identification Number (SIN):** SS4451
- **Maximum Working Pressure:** 175psi (12.1bar)
- **Discharge Coefficient (Nominal K-Factor):**
 - $K = 4.9 \text{ GPM/psi}^{1/2} (70.6 \text{ LPM/bar}^{1/2})$
- **Temperature Rating:**
 - 162°F (72°C), 205°F (96°C)
- **Color Code**
 - 162°F (72°C): Uncolored
 - 205°F (96°C): White
- **Vertical Adjustment:** 1/2 inch (12.7 mm)
- **Finishes:**
 - **Sprinkler:** Natural Brass, White Painted, Black Painted, Chrome Plated
 - **Recessed Escutcheon:** Brass Plated, White Painted, Black Painted, Chrome Plated

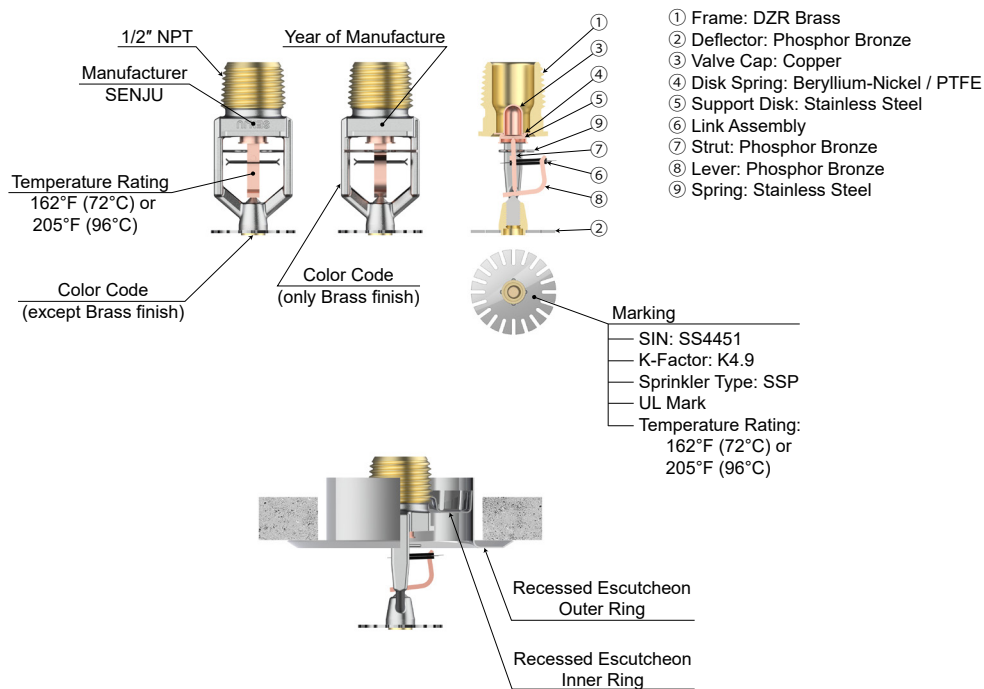

Figure 1: Model FR-RES K = 4.9

OPERATION

The sprinkler assemblies fusible link is comprised of two link halves that are joined together with a thin layer of solder. When the rated temperature is reached, the solder melts and the two link halves separate. This leads to the water flow to be distributed on the affected fire area.

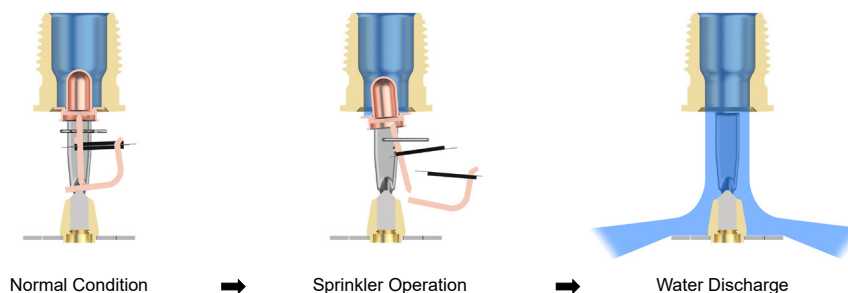

Figure 2: Operation Process (For illustrative purposes only)

DESIGN CRITERIA

The herein stated rules for use and installation of Model FR-RES are provided by the manufacturer and must be strictly implemented for safe and full results. Only the D1 or D3 Recessed Escutcheon, as applicable, is to be used for recessed pendant installations. D1 Recessed Escutcheons are not listed for use with the 205°F heads. D3 Recessed Escutcheons are required for the 205°F heads.

Notes

Residential Fire Sprinkler Systems should only be designed and installed by individuals who are completely familiar with automatic sprinkler system design, installation procedures, and techniques.

Several criteria may apply to the installation and usage of each sprinkler. Consequently, it is recommended that the sprinkler system designer review and develop a working understanding of the complete list of criteria prior to initiating the design of the sprinkler system.

Questions concerning sprinkler installation and usage criteria, which are not covered by the following instructions, should be submitted to your contracted company. Include sketches and technical details, as appropriate.

In some instances, the requirements of this document may concern specifications which are more stringent, and which take precedence over those specified in NFPA 13, 13D, 13R or by the authority having jurisdiction.

The spray from the sprinkler is distributed radially outward and downward from the sprinkler deflector. Consequently, the sprinklers must be located such that there will be no blind spaces shielded from spray by partitions, room dividers, overhangs or other parts of the dwelling structure.

The number of sprinklers within each compartment (as defined by NFPA 13D, 13R, or 13) must be kept as few as possible while observing all guidelines relating to obstructions and spacing.

The sprinkler must be secured in place by firmly fastening the sprinkler system piping to the structure. If the sprinkler is not properly secured in position, reaction forces resulting from sprinkler operation could alter its orientation and its water distribution pattern.

Obstruction to Water Distribution

Locations of sprinklers must follow the obstruction rules of NFPA 13, 13D and 13R for Residential Sprinklers.

General Service Conditions

The Model FR-RES must only be utilized in WET PIPE sprinkler systems.

Heat Source Criteria

Refer to NFPA 13D, 13R or 13 for the requirements relating to the prevention of possible activation of the Heat Responsive Element of Model FR-RES, due to the exposure of a heat source other than an actual fire.

Available Sprinkler Temperature Ratings		
Sprinkler Temperature Classification	Sprinkler Nominal Temperature Rating	Maximum Ambient Ceiling Temperature
Ordinary	162°F (72°C)	100°F (38°C)
Intermediate	205°F (96°C)	150°F (66°C)

Precautionary Warnings for Corrosive Environments

Model FR-RES sprinklers should not be installed where they may be subjected to a corrosive environment including the following:

1. Chlorine ion and Chloride environment

Stress corrosion cracking may be caused by exposure to environments with Chlorine ion and Chloride. Exposure to this environment may result in sprinklers operating under Non-Fire conditions or Not Operating when exposed to an actual fire.

2. Sprinkler system piping with Copper

Sprinkler systems should be constructed in compliance with the applicable standards and the requirements for copper piping when copper piping is used in the sprinkler system. (Reference standards NFPA 13, ASTM B813, B828, and CDA (Copper Development Association) – Solder Joint)

All residual flux must be removed from the interior and exterior of the copper piping by thoroughly flushing before installation of the Sprinkler Heads. Otherwise, residues of flux may cause corrosion and/or leakage in the sprinkler system.

Hydraulic Design Criteria

The minimum required sprinkler flow rates for systems designed to NFPA 13D or 13R are given in Table A as a function of temperature rating and the maximum allowable coverage area. The sprinkler flow rate is the minimum required discharge from the most hydraulically demanding sprinkler from each of the total number of “design sprinklers” as specified in NFPA 13D or 13R.

For systems designed to NFPA 13, the number of designed sprinklers is to be the four most hydraulically demanding sprinklers. The minimum required discharge from each of the four sprinklers is to be the greater of the following:

- The flow rates given in Table A for NFPA 13D and 13R as a function of temperature rating and maximum allowable coverage area.
- A minimum discharge of 0.1GPM/sq.ft. [4.07LPM/sq.m] over the “design area” comprised of the four most hydraulically demanding sprinklers for the actual coverage area being protected by the four sprinklers.

Table A. NFPA 13D & 13R Wet Pipe Hydraulic Design Criteria for Model SS4451

For systems with ceiling types smooth flat horizontal, or beamed, or sloped, in accordance with NFPA 13D, 13R or 13 as applicable.

Maximum Coverage Area ^(a) Ft. x Ft. (m x m)	Maximum Spacing Ft. (m)	Ordinary Temperature Rating 162°F (72°C)		Intermediate Temperature Rating 205°F (96°C)		Deflector to Ceiling	Installation Type	Minimum Spacing Ft. (m)
		Flow ^(b) GPM (LPM)	Pressure ^(b) PSI (bar)	Flow ^(b) GPM (LPM)	Pressure ^(b) PSI (bar)			
12 x 12 (3.7 x 3.7)	12 (3.7)	13 (49.2)	7.0 (0.48)	13 (49.2)	7.0 (0.48)	Smooth Ceilings 1-1/16 to 4 Inches. Beamed Ceilings per NFPA 13D, 13R or 13. Installed in beam 1-1/16 to 1-9/16 inches below bottom of beam.	Pendent or Recessed Pendent	8 (2.4)
14 x 14 (4.3 x 4.3)	14 (4.3)	13 (49.2)	7.0 (0.48)	13 (49.2)	7.0 (0.48)			
16 x 16 (4.9 x 4.9)	16 (4.9)	13 (49.2)	7.0 (0.48)	13 (49.2)	7.0 (0.48)			
18 x 18 (5.5 x 5.5)	18 (5.5)	17 (64.4)	12.0 (0.83)	17 (64.4)	12.0 (0.83)			
20 x 20 (6.1 x 6.1)	20 (6.1)	20 (75.7)	16.7 (1.15)	20 (75.7)	16.7 (1.15)			

- For coverage area dimensions less than the above mentioned, it needs to use the minimum required flow for the Next Higher Coverage Area listed.
- Requirement is based on minimum flow in GPM (LPM) from each sprinkler. The associated residual pressures are calculated using the nominal K-Factor. Refer to Hydraulic Design Criteria Section for details.

Sprinkler Spacing Criteria

The minimum spacing between sprinklers is 8 feet (2.4m). The maximum spacing between sprinklers cannot go beyond the coverage area calculated by using the specific hydraulic factors. (Ref. Table A)

INSTALLATION

The Model FR-RES must be installed in accordance with the following instructions:

NOTES

Do not use any sprinklers which have been subjected to potential mechanical damage. Do not use any sprinklers which show deformation or cracking in either the Sprinkler or the Protective Cap.

Prior to installation, sprinklers should be maintained in the original cartons and packaging until used to minimize the potential for damage to the sprinklers that could cause improper operation or non-operation.

The Protective Cap must remain on the sprinkler during installation. After the installation is completed, the Protective Cap must be removed to place the sprinkler in service.

Use a torque of 7 to 14 ft-lbs (9.5 to 19.0 N-m) to achieve a 1/2 inch NPT sprinkler joint. If you exceed the recommended maximum torque, this could result in damage to the sprinkler inlet, which may lead to leakage from the sprinkler.

Use only Spanner FR-S or Socket FR-H (or FR-H II) for installation of Model FR-RES sprinklers. Use of any other wrench or socket is prohibited and may cause damage to the sprinkler.

Do not over or under tighten the sprinkler due to an inadequate adjustment of the D1 or D3 Recessed Escutcheon.

Re-adjust the sprinkler fitting to correct the position.

Installation Steps

Install Model FR-RES sprinklers by the steps and figures shown below. Use only D1 or D3 Recessed Escutcheons with Model FR-RES sprinklers. (D1 Recessed Escutcheons are not listed for use with the 205°F heads. D3 Recessed Escutcheons are required for the 205°F heads.) Use of any other recessed escutcheon is prohibited and may void the warranty and approvals.

Model FR-RES sprinklers are only to be installed in the pendent position with the waterway perpendicular to the ceiling.

Step 1: Install the Inner Ring of the D1 or D3 Recessed Escutcheon over the sprinkler threads, as applicable. (Ref. Figure 3 and 4)

Step 2: Apply pipe-thread sealant to the threads. Begin hand-tightening the sprinkler into the sprinkler fitting in the pendent position.

Step 3: Using the Socket FR-H (or FR-H II) or Spanner FR-S, tighten the sprinkler into the sprinkler fitting with a torque of 7 to 14 ft-lbs (9.5 to 19.0 N-m). (Ref. Figure 5) A 1/2" drive ratchet (not included) is required for use with the Socket FR-H (or FR-H II).

Step 4: Remove the Protector by hand. (Ref. Figure 6) Slide on the Outer Ring of the D1 or D3 Recessed Escutcheon over the Sprinkler and push the Outer Ring over the Inner Ring until its flange comes in contact with the ceiling. (Ref. Figure 7)

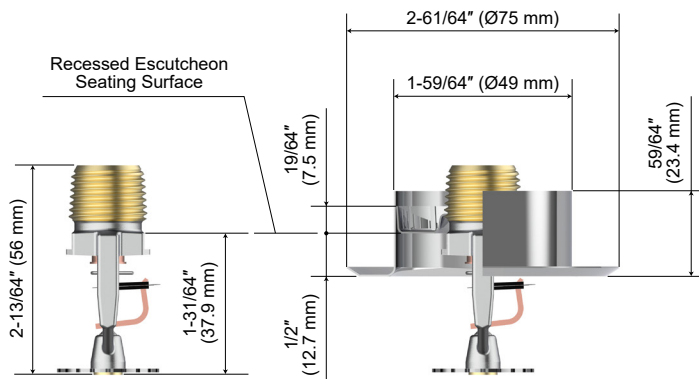

Figure 3: Pendent and Recessed Pendent Sprinklers

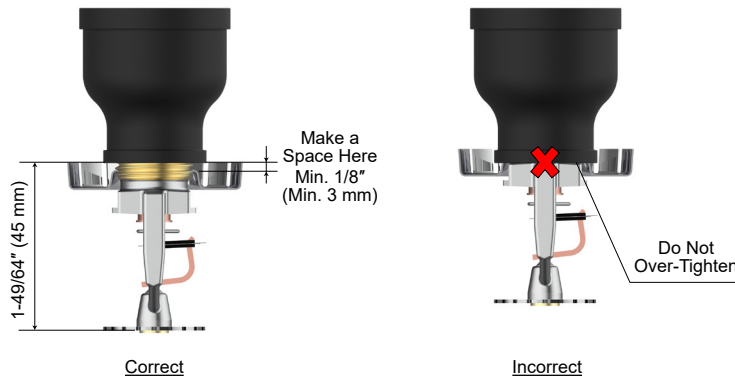

Figure 4: Installation (Correct and Incorrect)

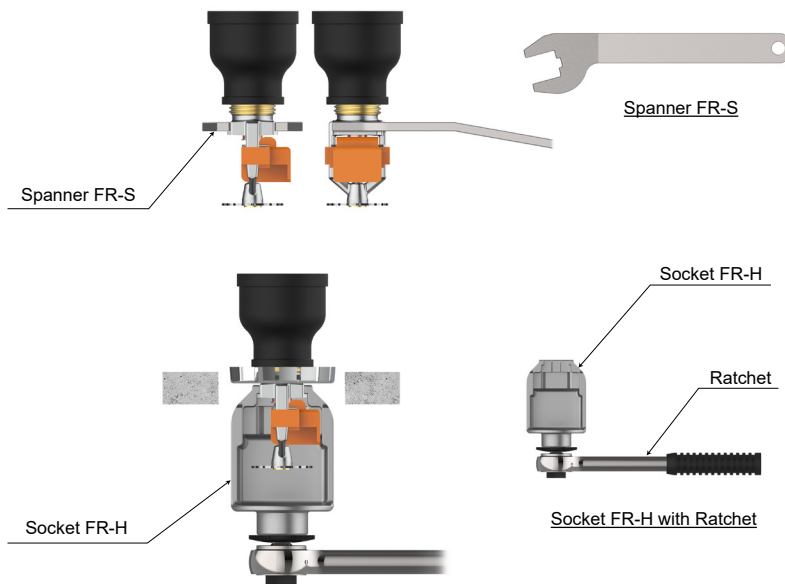

Figure 5: Installation (Spanner and Socket)

A 1/2" drive ratchet (not included) is required for use with the Socket FR-H.

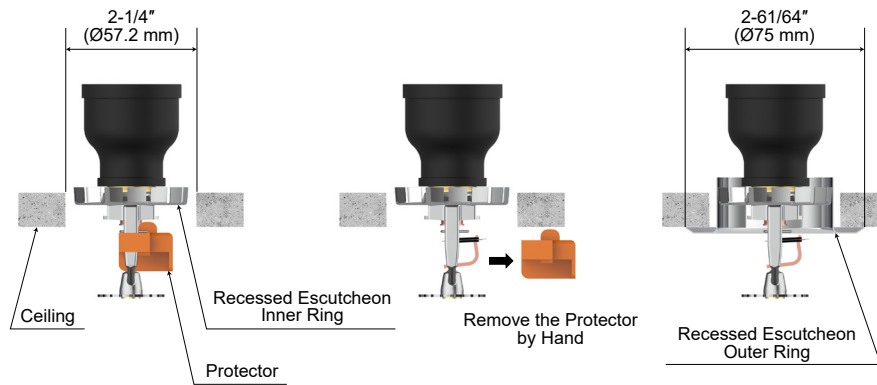

Figure 6: Protector Removal

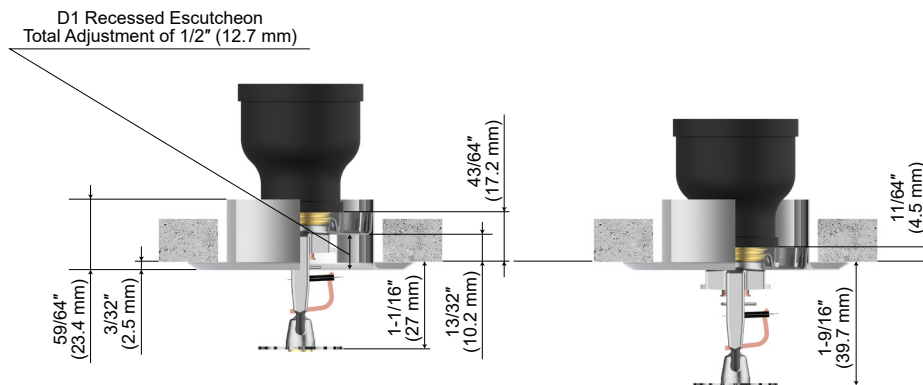

Figure 7: Installation (Recessed Escutcheon)

CARE & MAINTENANCE

The following instructions must be implemented for the maintenance and service of the Model FR-RES.

Notes

Wet pipe sprinkler systems must be maintained at a minimum temperature of 40°F / 4°C to prevent freezing and bursting of the pipe and/or sprinklers.

Automatic sprinklers are not to be tested with a heat source. Operation of the heat responsive element can result.

Absence of the Outer Ring from the D1 or D3 Recessed Escutcheon, which is used to cover the clearance hole, can delay sprinkler operation in a fire situation.

In preparation for maintenance of the fire protection system, permission to close the main control valve must be obtained from the proper authorities, and all affected parties by this action, and must be informed before the maintenance session can commence.

Do NOT enclose any sprinklers within drapes, curtains, or valances.

Do NOT hang anything from the sprinklers.

Do NOT clean the sprinklers with soap and/or water, detergents, ammonia, cleaning fluids, or other chemicals.

Remove dust, lint, cobwebs, cocoons, insects, and larvae by gently brushing with a feather duster or gently vacuuming with a soft bristle (i.e., dusting) brush attachment.

Exercise suitable safety precautions in the use and storage of highly flammable materials. The rapid rate of fire development and spread of these materials can reduce the ability of the sprinkler system to aid in the control of a fire involving such hazards.

Leaking or corroded sprinklers must be replaced.

Automatic Sprinklers must be kept in a cool and dry place.

Automatic sprinkler must never be physically altered, such as painted, plated, or coated, once shipped from the factory. If the sprinklers have been in any way modified, they must be replaced.

Great caution must be applied to prevent damage to the sprinklers at all stages - before, during, and after installation. Damaged units because of dropping, hitting, over-tightening, or wrench slippage, must be replaced.

The Model FR-RES must only be replaced with pendent sprinklers which are listed for residential fire protection service and which have the same nominal K-Factor, the same coverage area, and the same or lower flow ratings (as indicated under Table A "Hydraulic Design Criteria").

When remodeling, such as by adding false beams or light fixtures or changing the location of compartment walls, first verify that the new construction will not violate the installation requirements of the applicable standards of NFPA. Alter the new construction and/or the sprinkler system to suit the requirements of this document and the applicable NFPA regulations.

The owner is responsible for the maintenance of the sprinkler system, including inspection and testing of its compliance with this document, as well as the standards of the National Fire Protection Association (e.g., NFPA 25), and the regulations of any other authorities having jurisdiction. The owner should direct any questions regarding the above rules and regulations to the installing contractors or the sprinkler manufacturer. It is recommended that automatic sprinkler systems be inspected, tested, and maintained by a qualified Inspection Service in accordance with NFPA 25.

LIMITED WARRANTY

For details of warranty, refer to Sales Contract.

ORDER PROCEDURE

When placing an order, please contact a local distributor with the following information (Model Name, Temperature Rating and Finish).

Sprinkler

- Model: FR-RES K4.9
- Temperature: 162°F (72°C) or 205°F (96°C)
- Finishes: Natural Brass, White Painted, Black Painted, Chrome Plated
For SIN and combination of Recessed Escutcheon, refer to the table below.

Type	SIN	Temperature	Recessed Escutcheon
Pendent	SS4451	162°F, 205°F	--
Recessed Pendent		162°F	D1 (1/2" total adjustment)
Recessed Pendent		162°F, 205°F	D3 (1/2" total adjustment)

Recessed Escutcheon

- Model: D1 Recessed Escutcheon (Inner Ring and Outer Ring, 1/2" total adjustment)
- Model: D3 Recessed Escutcheon (Inner Ring and Outer Ring, 1/2" total adjustment)
- Finishes: Brass Plated, White Painted, Black Painted, Chrome Plated

Tools and Accessories

- Spanner FR-S (Open-end wrench type)
- Socket FR-H or FR-H II (Socket wrench type)
For use with a 1/2" drive ratchet (not included)