

No. of Parts	Name of Parts	Material	Qua'ty	Remarks	No. of Parts	Name of Parts	Material	Qua'ty	Remarks
1	Body	C69300	1		13	Cylinder	C5441 or C5341	1	
2	Compression Screw	SUS304 or SUS303 or SUSXM7	1		14	Plunger	SUS303	1	
3	Disk	C69300	1		15	Heat Collector (U)	C1100 or C1020	1	
4	Button	C3604	1		16	Heat Collector (L)	C1100 or C1020	1	
5	Saddle	SUS304	1		17	Cup	SGCC or SECC	1	
6	Guide Pin	SUS304 or SUSXM7	2		18	Retainer	SPCC	1	Cu-Plated
7	Gasket	PTFE	1		19	Cover Plate	C1100 or C1020	1	※
8	Deflector	C5191	1		20	Ejection Spring	SUS304-CSP	1	
9	Lever	SUS304	2		21	Base	SGCC or SECC or SPCC	1	
10	Supporting Plate	SUS304	1		※Finishes ; Nickel plated, White Painted Any Color Painted (Choose one color of our acceptable color list.)				
11	Set Screw	SUS304 or SUS303 or SUSXM7	1						
12	Balancer	SUS304	1						

### Specification

Type	RC-QR 162°F	
Operating Temperature	Cover Plate	140°F (60°C)
	Sprinkler Head	162°F (72°C)
Installation Position	Pendent	
K-Factor	5.6	
ID No.	SS9561	
Cover Plate Assembly	φ 68 or φ 83	

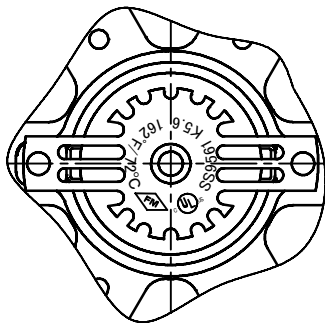

View: P

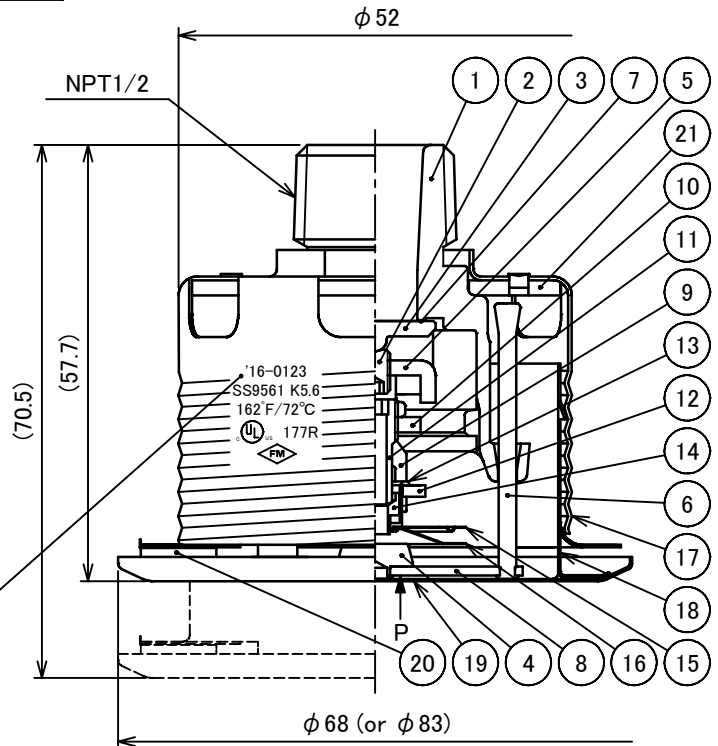

### Marking

- ex.'16-0123 : Lot No. (Year of Manufacture)
- SS9561 : SPRINKLER IDENTIFICATION No.
- K5.6 : K-factor
- 162°F/72°C : Temperature Rating
- UL<sub>US</sub> : UL Mark
- 177R : Control No.
- FM : FM Approval Mark

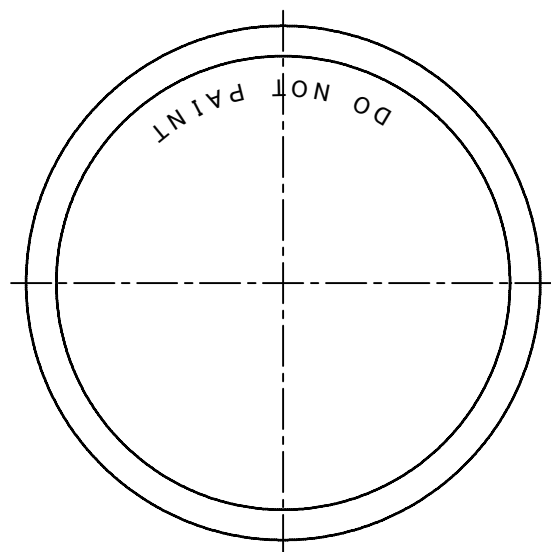

UL and C-UL Listed / as Quick Response  
FM Approved / as Standard Response

Drawing Name	Issued Date : 16/05/09	Drawing No.	Revision
<b>Automatic Sprinkler Head</b> <b>RC-QR K5.6</b>	Projection Angle 3 r d	<b>E036880</b>	<b>B</b>
	Scale : 1 / 1		
			<b>SENJU SPRINKLER CO.LTD.</b>