

Senju Sprinkler



EXTERIOR ACCESS DOOR / PANEL MODEL: SS-AP244

The SS-AP244 is a robust, high-quality exterior access panel with advanced water resistant technology. Its thermoplastic EPDM rubber gasket provides excellent compression and temperature durability, ensuring a reliable and long-lasting seal suitable for various exterior applications. Additionally, excellent for water penetration resistance: no leakage at 2.92 psf – ASTM E 331

SPECIFICATIONS

Door:	18 gauge galvanized steel
Frame:	18 gauge galvanized steel welded frame with 1" wide flange
Hinge:	Concealed Pin Hinge
Latch:	Screwdriver-operated cam latch
Optional Lock:	Cylinder lock and key
Insulation:	13/16" (21 mm) Polyurethane board with Aluminum foil
Gasket:	Trim seal with EPDM rubber bulb
Finish:	White (RAL 9016) powder coating

STANDARD SIZES

Panel Size W x H (Inches)	Part Number	Wall/Ceiling Opening (Inches)	# of Latches	Weight (Lbs.)
14 X 14	90000-140-0302	14-1/8 X 14-1/8	1	9.5
14 X 24	90000-140-0202	14-1/8 X 24-1/8	2	15

EXTERIOR ACCESS PANEL DETAILED SIZES

14 x 14 Exterior Access Panel

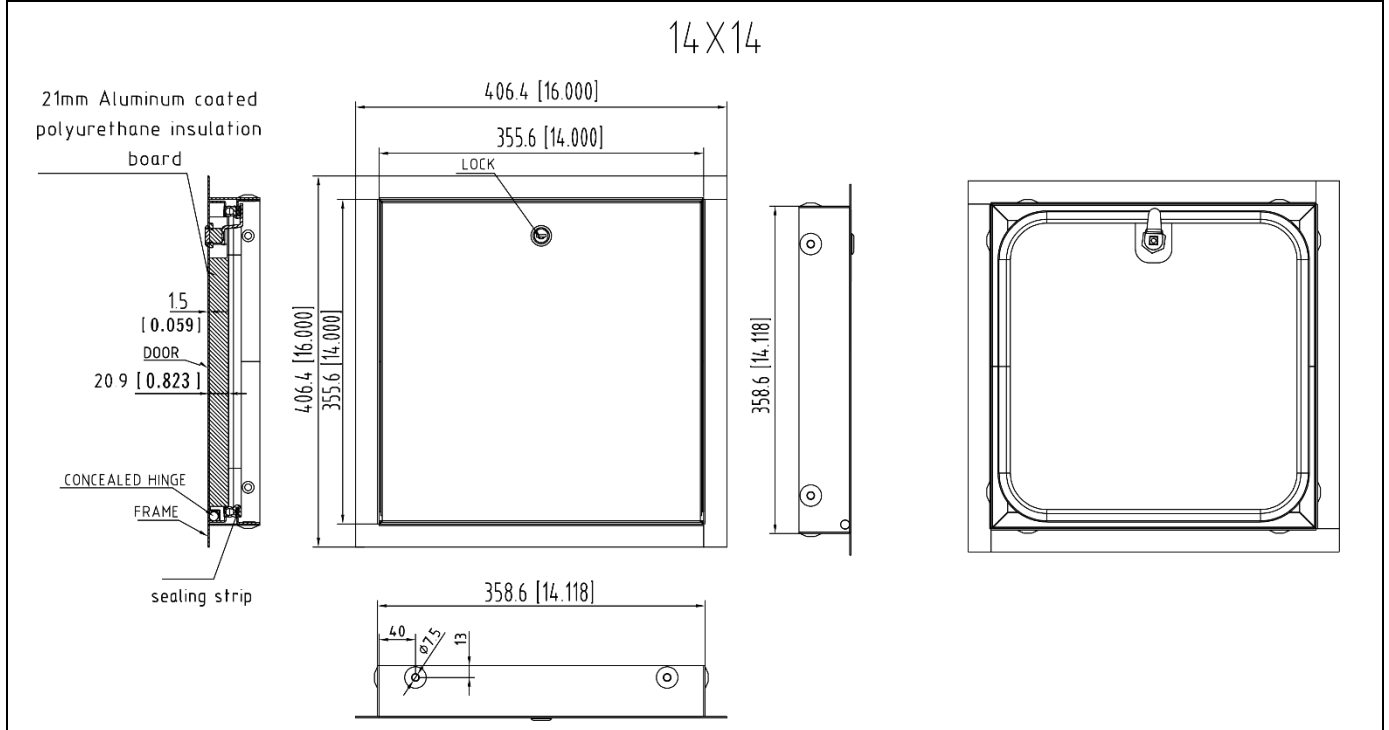

14 x 24 Exterior Access Panel

